

Double A Frame Bridge Construction

Step 1 – Appoint a Safety Officer, Signal Caller, and Project Leader

- Appoint a project leader.
- Appoint safety officer – the safety officer had absolutely no other duties
- Appoint a signal caller for raising the bridge frames..

Step 2 – A Frame Materials

Acquire the following materials:

- 8 – 4" x 8' Spars
- 4 – 3" x 6' Spars
- 6 – ¼" x 15' Ropes
- 2 – ¼" x 10' Ropes

Step 3 – Build the A Frames – The first step in building the monkey bridge is to build four A frames using 8' spars for the two legs and 6' spars for the ledger.

- Lay out the first set of three spars (two legs and one ledger) on the ground in position for lashing
- Before lashing, drive three stakes to help you make all four A frames the same size.
 - Drive a stake at the top to mark where the leg spars cross.
 - Drive stakes to mark the positions of where the bottom ledger crosses the legs.
- Lash the four A frames together one at a time using square lashings. Use ¼" – 15' ropes.

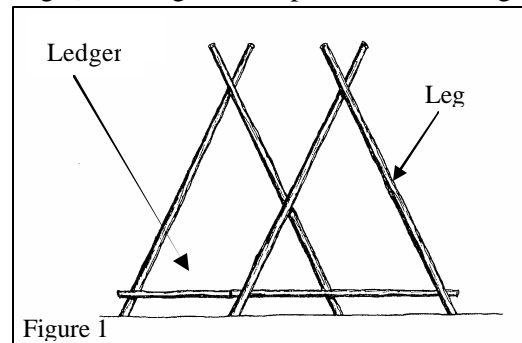

Step 4 – Lash the A Frames Together

- Lay one A Frame on the ground and then put another on top of it as shown in the above figure. The bottom ledgers should overlap one half of their length. See Fig. 1.
- Place a tight square lashing where the legs of the two A Frames cross. Use ¼" – 15' ropes.
- After the A Frames are lashed together at the X between the two legs, stand the A Frames up so the butt end of the legs rest solidly on level ground.
- Lash the two bottom ledgers together using three strop lashings. A strop lashing is nothing more than wrapping the rope around the ledger several times and then tie off with a square knot. Use ¼" – 10' ropes.
- Repeat the process for the other set of A Frames.

Step 5 – Site Preparation Materials

Acquire the following materials:

- Roll of Binder Twine
- Measuring Tape

Step 6 – Site Preparation – Before you can erect the double A frames, prepare the site.

- Stretch a length of binder twine along the center where the monkey bridge will be built.
- Working from the center of the twine, measure 10' toward each end to mark where the A Frames will be placed. The A Frames should be 20' apart.

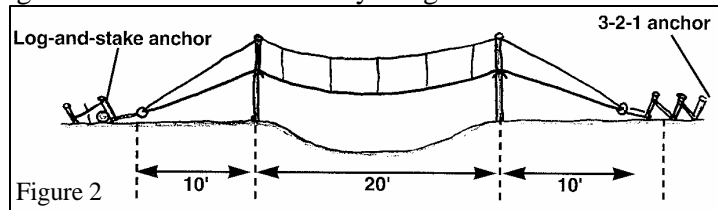

- Then mark another 10' from each A Frame to mark where the anchors will be built. See Fig 2.

Step 7 – Anchor Materials – You may use one 3-2-1 Anchor and one Log-and-Stake Anchor or two 3-2-1 Anchors or two Log-and-Stake Anchors. The materials shown below are for one 3-2-1 Anchor and one Log-and-Stake Anchor

3-2-1 Anchor

- 6 – 2" x 4" Popular Stakes
- Mallet
- 2 – ½" x 15' Rpes
- 2 – Small Stakes for Tourniquet

Log-and-Stake Anchor

- 1 – 4" or 6" x 6' Log
- 8 – 2" x 4" Popular Stakes
- Mallet
- 1 – ½" x 15' Ropes
- 4 – Small Stakes for Tourniquet
- 4 – ¼" x 10' Ropes
- 1 – Shackle or Ring

Step 8 – Building the Anchors – The foot ropes will be attached to the anchors at both ends. Build a 3-2-1 anchor or a log-and-stake anchor 10' from where the double A frames will be erected.

3-2-1 Anchor

- Drive stakes in a series: three stakes, then two stakes, then one stake. See Fig. 3.
- All stakes are 30" long and driven 18" into the ground at an angle of 20°.
- The two-stake set is 24" away from the three-stake set. The single stake is 12" away from the two-stake set.
- Tie a rope from the top of the three stake set to the bottom of the two stake set using at least two loops of ¼" manila rope. Use a small stick to twist the rope tight as in a tourniquet. Push the end of the stake in the ground to keep it from unwinding.
- Tie a rope from the top of the two stake set to the bottom of the single stake using at least two loops of ¼" manila rope. Use a small stick to twist the rope tight as in a tourniquet. Push the end of the stake in the ground to keep it from unwinding.

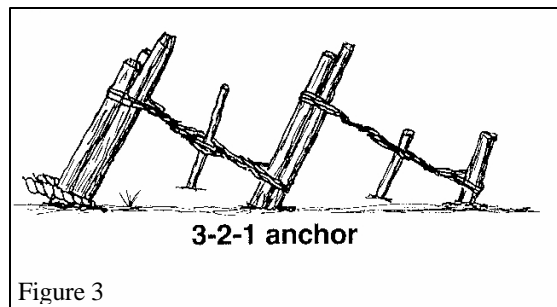

Log-and-Stake Anchor

- Place a log 4" to 6" in diameter perpendicular to the pull of the line. See Fig. 4.
- Drive four large stakes in front of the log.
- Slip a rope grommet through a ring and then slip the ends of the grommet around the log.
- Drive a second row of stakes 24" behind the front stakes.
- Anchor the front stakes to the rear stakes with a tourniquet made of rope. Secure the stick winding the tourniquet rope into the ground.

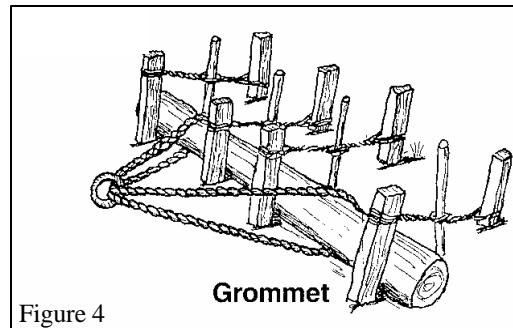

Step 9 – Build a Rope Grommet – After the anchors are built, attach a rope grommet with a ring or shackle in it. You may use a rope ring.

Step 10 – Position the A Frames – Prepare to erect the bridge by moving the A Frames no more than 20' apart. Lay them down on the binder twine that marks the center of the bridge

Step 11 – Footrope, Handropes, and Stringer Materials

Acquire the following materials:

- 1 – 1/2" or 3/4" x 50' Rope
- 2 – 1/2" x 50' Handropes
- 5 – 1/4" x 10' Stringer ropes

Step 12 – Hand and Foot Ropes

- Lay the footrope in a straight line off to the side of where the A Frames are lying.
- Lay the two hand ropes on the ground so they are parallel to the footrope and 42" away on each side of the foot rope.

Step 13 – Stringer Ropes

- Tie a stringer to the midpoint of the footrope. Use 1/4" – 10' manila rope. Use a clove hitch. 5' of rope should be left on each side of the stringer. See Fig. 5.
- Add two more stringer ropes on both sides of the center stringer rope. Each string is about 4' from an adjacent stringer.
- Tie one end of each stringer rope to one of the hand ropes using a clove hitch. Ensure that the distance between the footrope and the hand ropes is maintained at 42".
- Tie the other end of the stringers to the other hand rope using clove hitches.
- More stringers may be applied later.

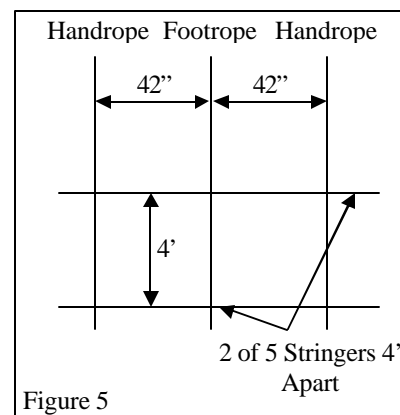

Step 14 – Assemble Bridge Materials

Acquire the following materials:

- 2 – Canvas Pieces
- Roll of Binder Twine

Step 15 – Assemble the Bridge

- Place a heavy piece of canvas in the V formed by both A Frames. This protects the foot rope and allows it to slide a little in the V without interference with the lashing rope.
- Get the crew together to erect the bridge.
- You will need a safety officer to watch for any problems that might occur.
- Use two Scouts to lift and hold each double A Frame. Don't lift yet.
- Use two Scouts to lift the footrope into the V of the double A Frames.
- Use two Scouts to lift the hand ropes and place them at the tops of the A Frames.
- Lift the A Frames. While holding the A Frames, temporarily tie the hand and foot ropes into the rings on the grommets using a roundturn and two half hitches. See Fig. 6.

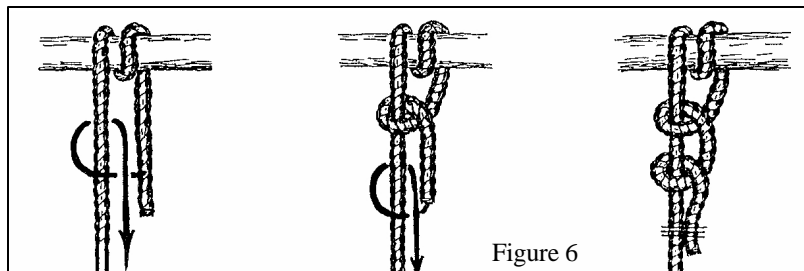
**Step 16 – Tighten the Foot Rope**

- Have three Scouts pull on one end of the footrope.
- Tighten it with the round turn and two half hitches.

Step 17 – Tighten the Hand Ropes

- Tie the hand ropes to the tops of the A Frames.
- Loosen one end at a time from the anchors.
- Use a clove hitch to tie the handrope to the top end of the leg of the double A Frame. As you tie the clove hitches, match the sag of the hand rope to that of the footrope.
- After the hand ropes are tied to the top of the A Frames, retie the ends of the hand ropes to the rings in the grommet using a roundturn and two half hitches.

Step 18 – Final Testing

- One crew member gets on the bridge while all lashings, anchors, and knots are observed by the safety officer.
- Make adjustments as required. Secure the running ends of the roundturns and two half hitches with twine.
- Only one Scout on the bridge at a time.